

# 5.5" 12G-SDI Triple

---

## Rack-mount Monitor

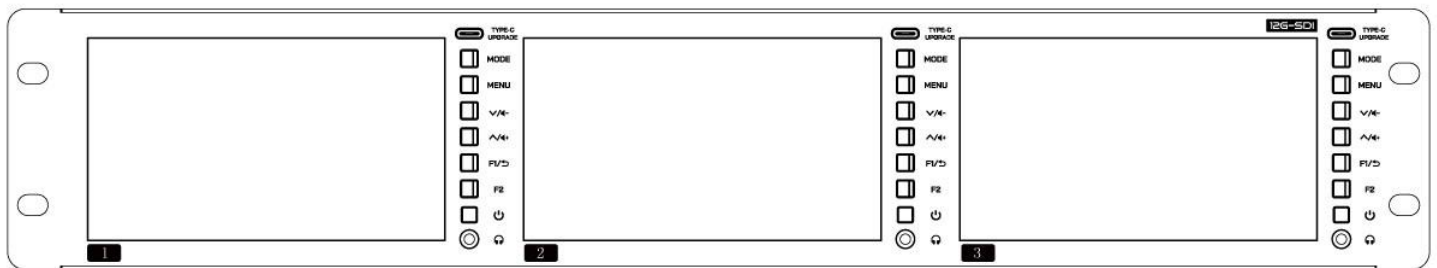

# User Manual

## **1. Product Overview**

Thank you for using our photography, broadcast kits Dual Rack Mount Multi-Functional Color LCD Monitor. This monitor adopts advanced integrated circuits, high-quality IPS LCD panel, which makes it low power consumption, stable performance, no radiation, strong compatibility, and adjustable color temperature control etc. Our monitor has the HDMI 2.0 and 12G-SDI single-link digital serial interface input & output port, meet the higher quality monitoring needs.

**To ensure best use of the unit, please read the user's manual carefully.**

### **CAUTION**

1. Please use the adapter attached in the accessory, if necessary, please use qualified adapter.
2. Please do not store or use in too cold, too hot or humid place.
3. Please keep the monitor away from the strong light while using this product to ensure the image effect and long-term use.
4. Please avoid heavy impact or drop onto the ground.
5. Please do NOT use chemical solutions to clean this product. Please wipe the monitor with a clean soft cloth to maintain the brightness of the surface.
6. No adjustable components in the monitor. Please do not take apart or repair the unit by yourself, to avoid the damage of the product.

# KEY FEATURES

- ◆ Triple 5.5-inch full HD 1920x1080 IPS
- ◆ 2RU rack mount design, suitable for news production, post production, and broadcasting trucks, special vehicles video surveillance and other fields
- ◆ Flexible and intuitive button operation
- ◆ New menu interface, software function iconized
- ◆ Accurate full waveform analysis and monitoring
- ◆ Supports 3D LUT Log to REC.709 and user 3D LUT upload (up to 32)
- ◆ With Vector, Histogram, False Color, Monochrome etc. functions, can help you accurately exposure and focus every shot.
- ◆ Front panel stereo earphone output.
- ◆ Equipped with HDMI, 12G-SDI inputs and outputs, meet the higher quality monitoring needs
- ◆ Remote control the monitor menu and functions through LAN port
- ◆ 3-color Tally indicator light, enhance the team cooperation

# CONTENTS

<b>1. Product Description</b>	<b>4</b>
<b>1.1 Front Panel Features</b>	<b>4</b>
<b>1.2 Rear Panel Features</b>	<b>5</b>
<b>1.3 Power Input Way</b>	<b>6</b>
<b>1.4 TALLY Indicator Connection</b>	<b>7</b>
<b>2. Ethernet Connection</b>	<b>8</b>
<b>3. Menu Function Introduction</b>	<b>13</b>
<b>4. Custom LUT Load Instruction</b>	<b>21</b>
<b>5. Support Signal Formats</b>	<b>22</b>
<b>6. Parameters</b>	<b>22</b>
<b>7. Trouble Shooting</b>	<b>23</b>

# 1. Product Description

## 1.1 Front Panel Instruction

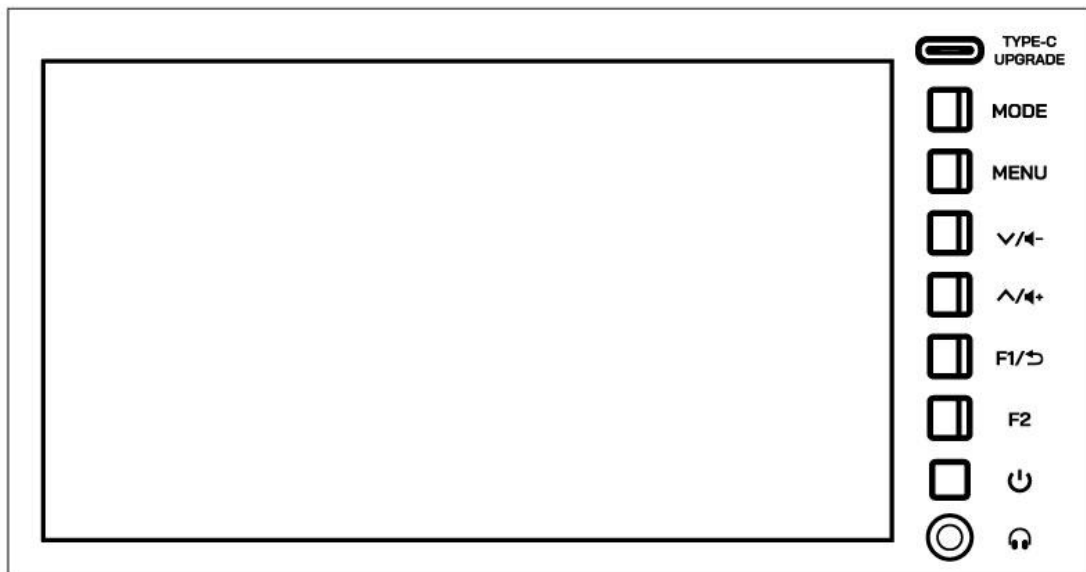
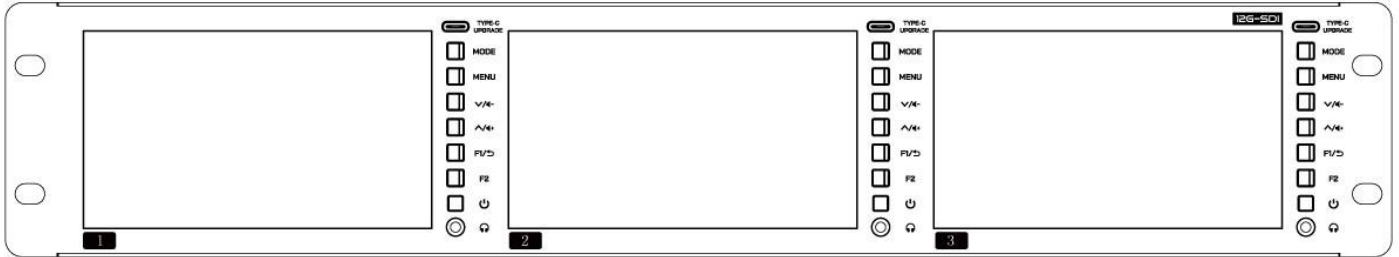

<b>Type-C UPGRADE</b>	Firmware update; LUT file import
<b>MODE</b>	Input signal selection and confirm
<b>MENU</b>	Menu button, enter/confirm
<b>V/◀</b>	Next item selection/parameters increasing after enter the menu; Volume decrease adjustment when menu without display

	Previous item selection/parameters decreasing after enter the menu;  Volume increasing adjustment when menu without display
<b>EXIT</b>	Exit the menu
<b>F1/↵</b>	Custom function shortcut button; Menu return/exit
<b>F2</b>	Custom function shortcut button
	Standby Power Key
	Earphone jack port

## 1.2 Rear Panel Features

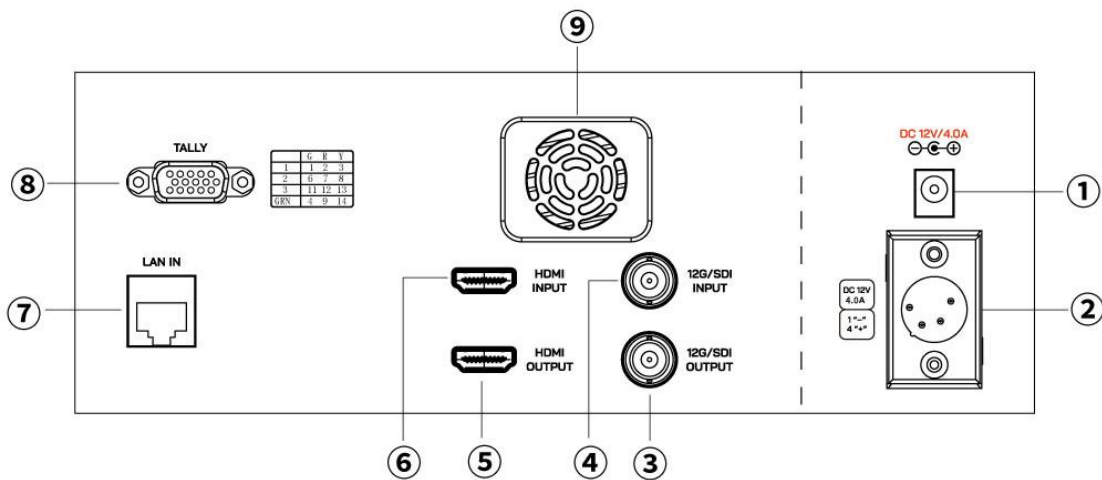
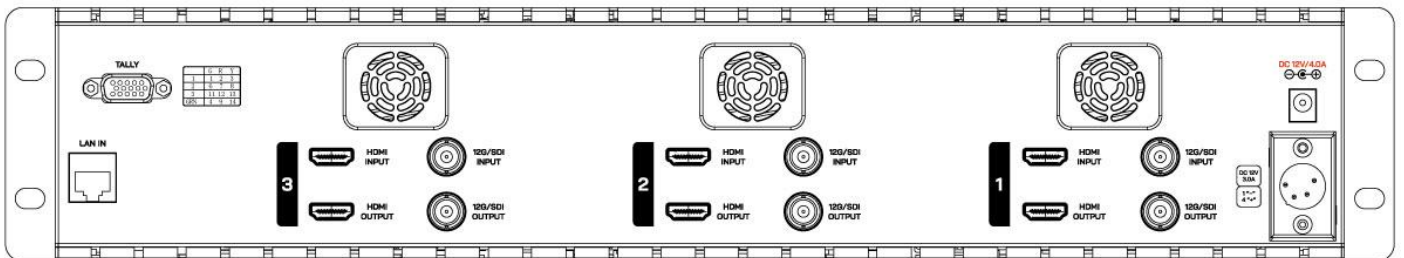

①	/	DC 12V Power Input
②	/	4-pin XLR DC12V power input
③	12G/SDI OUTPUT	12G-SDI single-link digital serial input
④	12G/SDI INPUT	12G-SDI single-link digital serial input  IN(Composite video broadcast signal input) OUT(Composite video broadcast signal output)
⑤	HDMI OUTPUT	HDMI 2.0 signal output
⑥	HDMI INPUT	HDMI 2.0 signal input
⑦	LAN IN	LAN Connector
⑧	TALLY	TALLY signal input port
⑨	/	Cooler

### 1.3 Power Input Way

There are two ways of power supply to our monitor:

- A. The direct plug-in DC power input port supply. Please use DC5.5\*2.1m DC power plug, the monitor provides a DC 12V/4A power adapter to power supply. Power input polarity as shown

below:



B. Via 4 pin XLR interface power supply.

Polarity of the 4-pin XLR power input as shown below, please note the polarity of the power input, otherwise it may damage monitor.

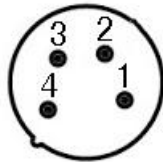

Pin number	Signal
1	GND
2	No connection
3	No connection
4	+12V

### 1.4 TALLY Indicator Connection

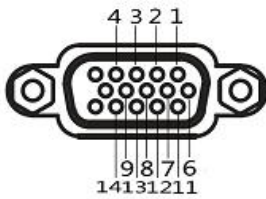

Screen #1	Screen #2	Screen #3	Tally
1	6	11	Green Light
2	7	12	Red Light
3	8	13	Yellow Light
4	9	14	Ground

## 2. Ethernet Connection

Our monitor is equipped with Ethernet interface, and users can connect the PC with our monitor through the Ethernet port. Users can use the software to control the monitor and send their control and command to the specific monitor, as follows:

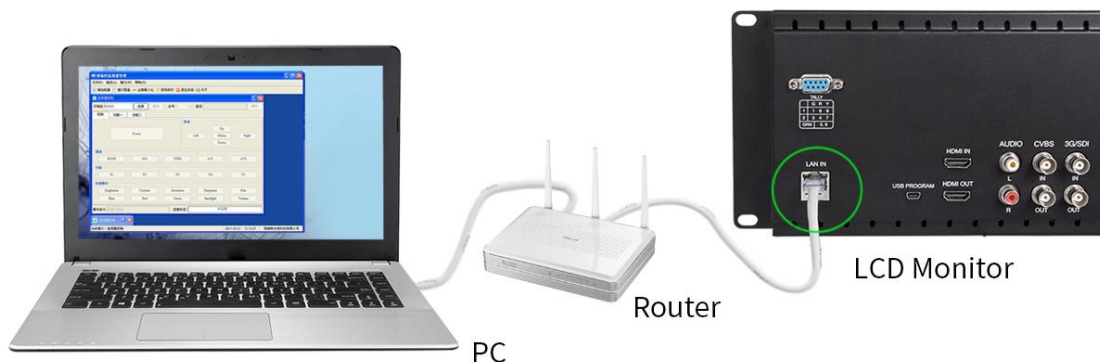

Connect the LAN port on the back of the monitor to the network. After connection, the monitor will display the same IP address with that device.

Get the control software: Download from the details page of FRM701G from website [www.feelworld.cn](http://www.feelworld.cn)



After downloaded open file

, Double Click

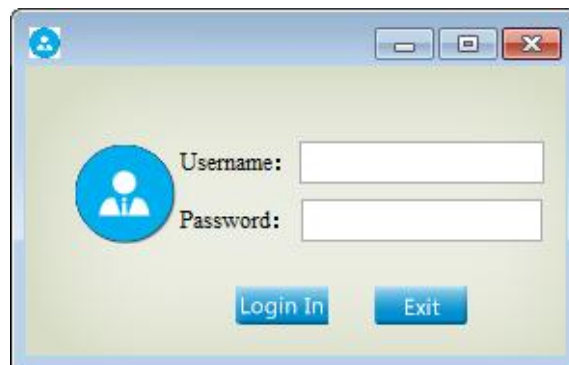
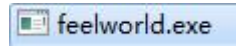

Then, Input:

Username: admin

Password:123456,

Click Login In

After login in, Click: Add monitor

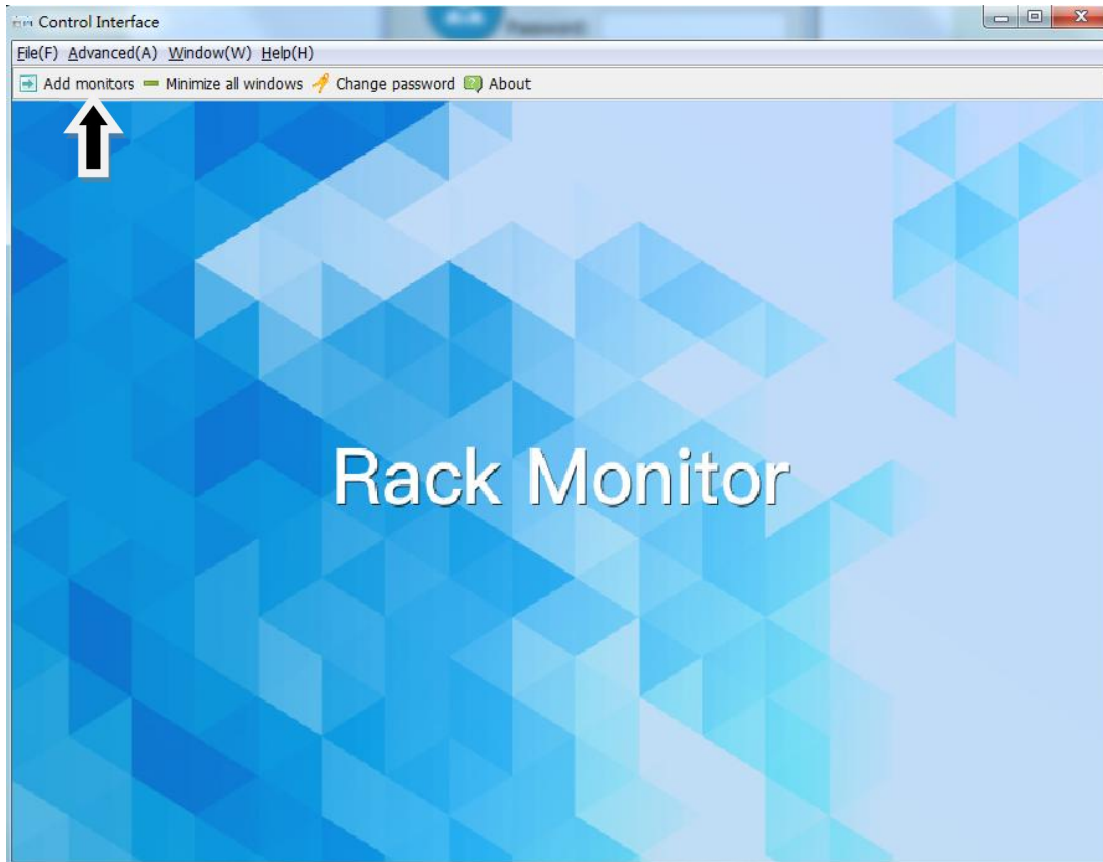

Input IP address (The same as the IP address displayed on the monitor.)

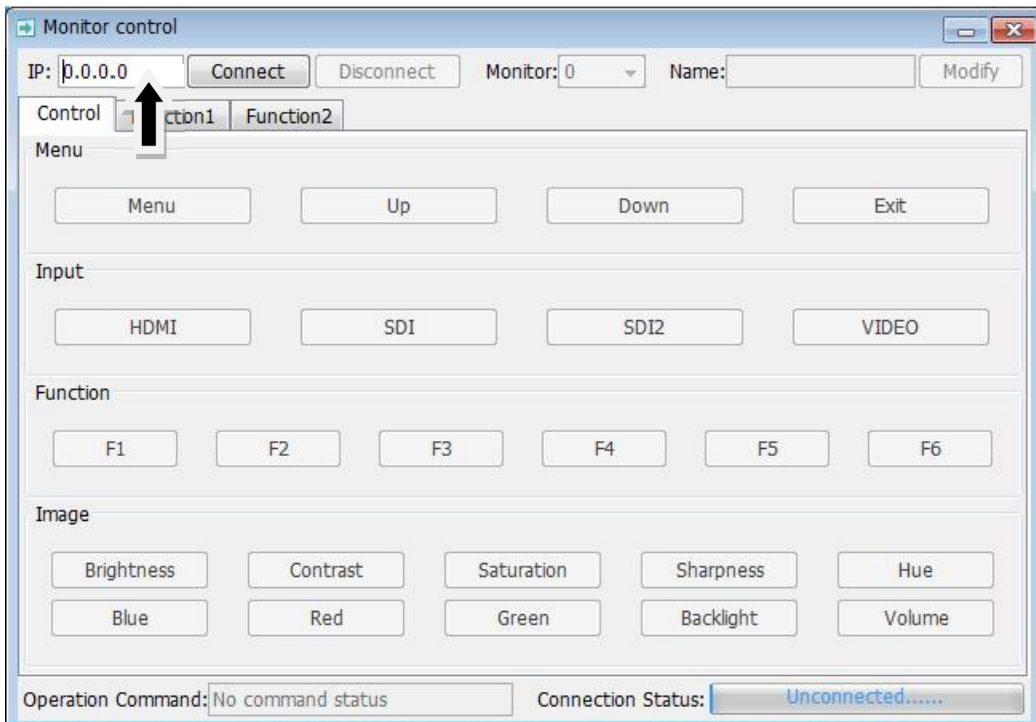

Select the controlled monitor (number 0 control left monitor, number 1 control right monitor)

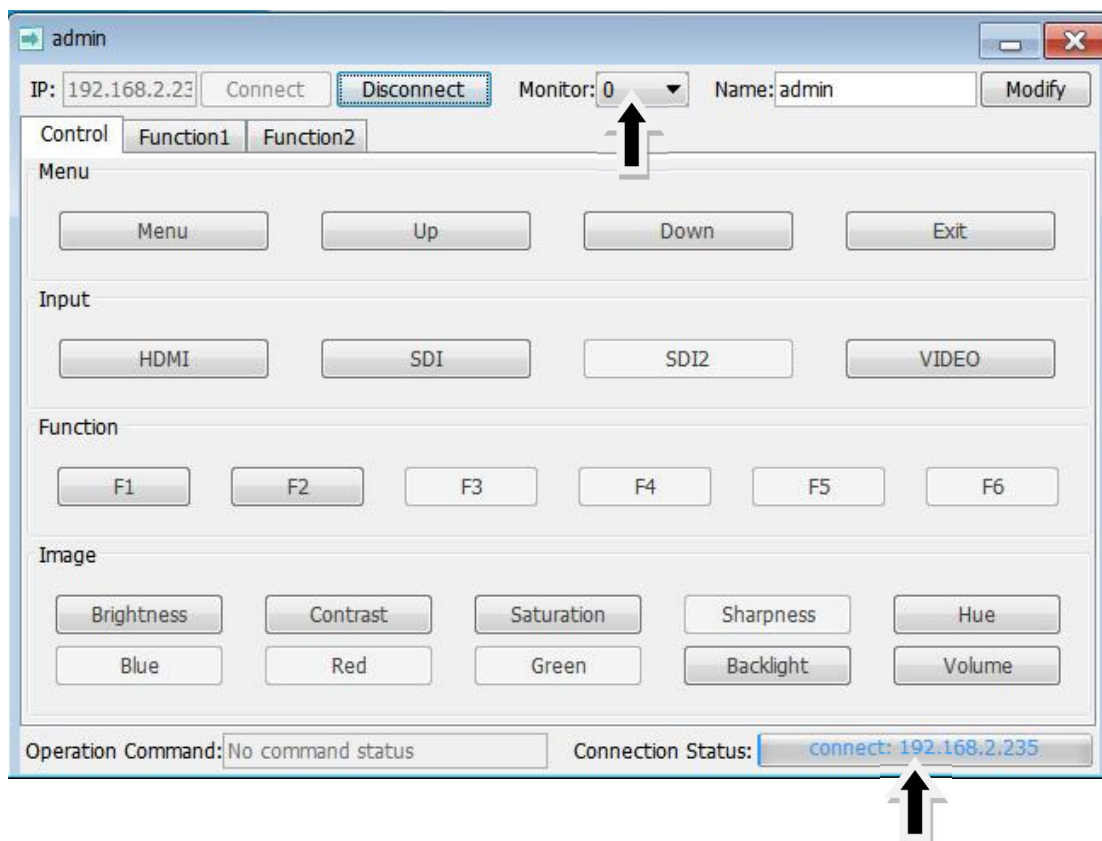

Check: Connection Status,

If connected, the IP address will be displayed. e.g:



Then users can click the corresponding control bar to control and command the parameters:

### Control:

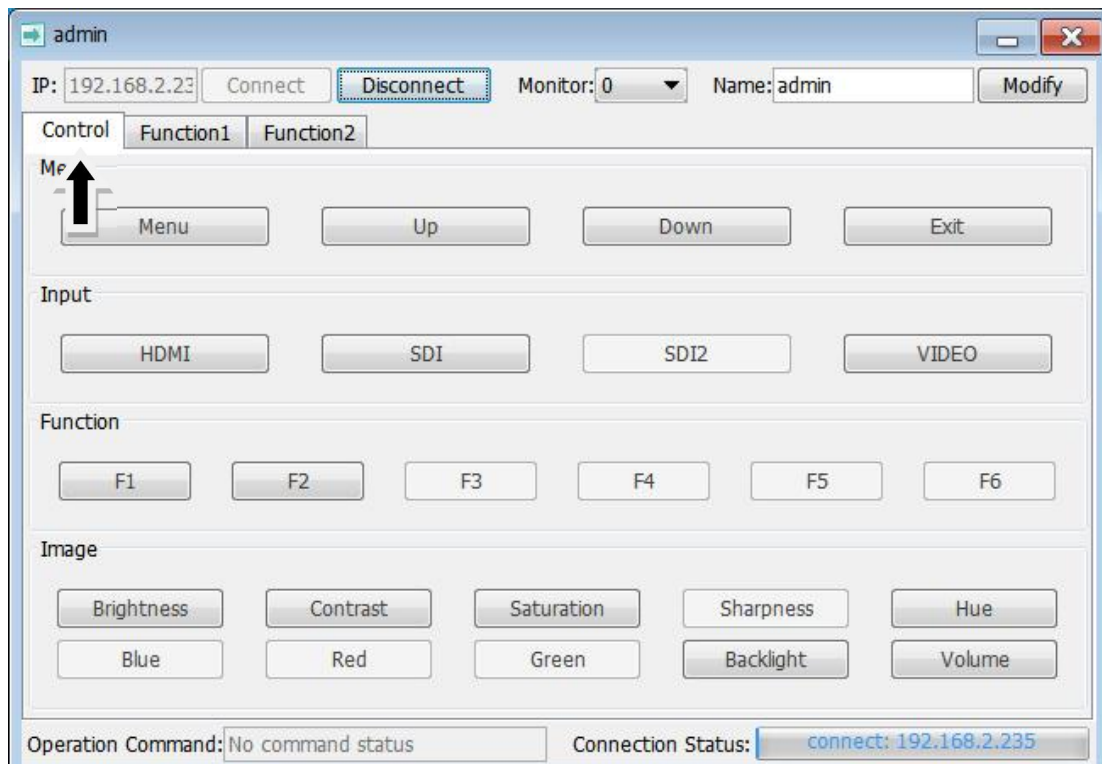

### Function1:

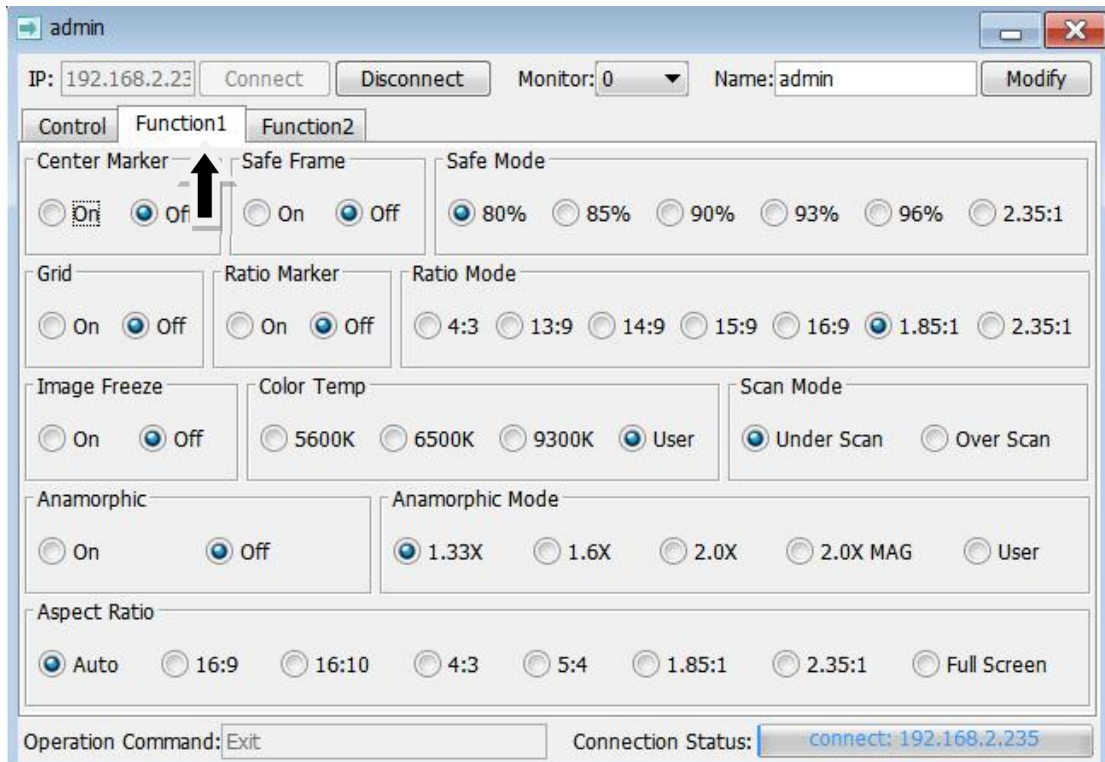

## Function2:

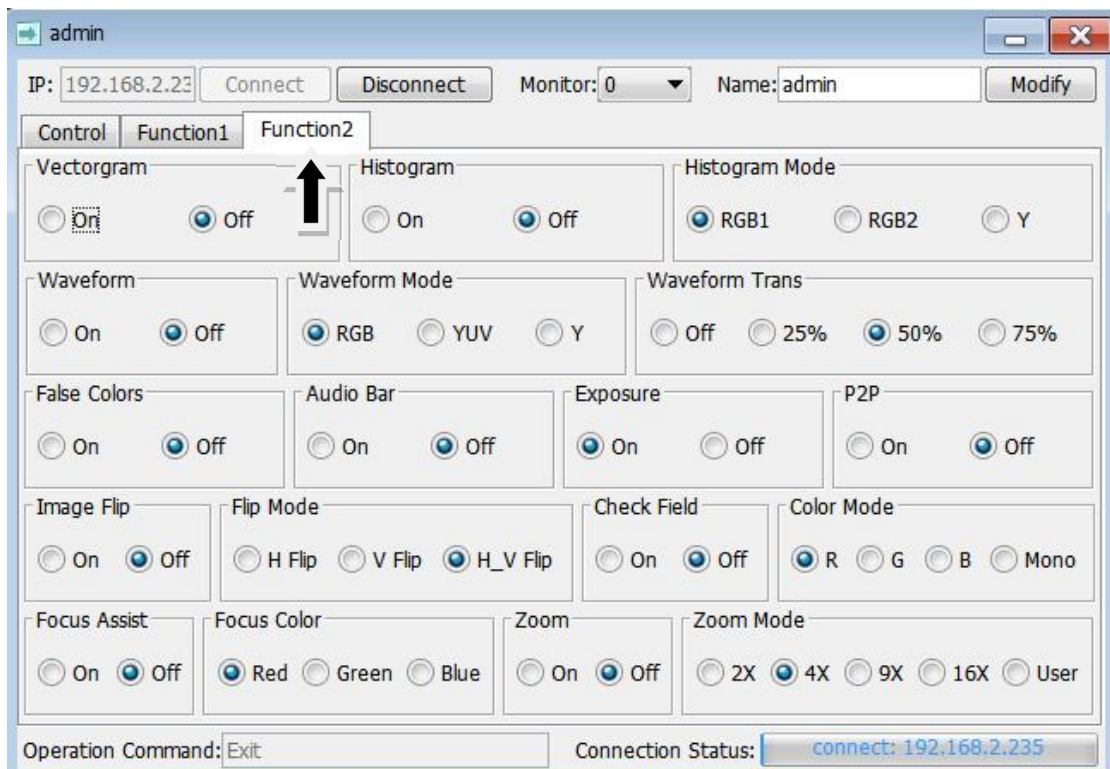







### 3. Menu Function Instruction



#### Functional Assist

<b>All Waves</b>	<p><b>On, Off</b></p> <p>After turning on, waveform, vector, histogram and embedded audio will be shown.</p>
<b>Waveform</b>	<p><b>On, Off</b></p> <p><b>Mode : RGB, YUV, Y</b></p> <p><b>Waves Trans. : Off, 25%, 50%, 75%</b></p> <p>The waveform is a core tool for professional video production. It converts the brightness and color information of the frame into visual curves, enabling precise control of exposure, white balance and color balance, preventing overexposure, crushed blacks or color casts in the frame, ensuring the signal meets broadcast standards. It is ideal for scenarios with vary light, complex composition or cinematic video.</p> <p>The X-axis of the waveform monitor corresponds to the horizontal position of the frame (left to right), and the Y-axis represents the brightness level of each position, generally defined with black as the 0 line and maximum brightness as the 100 line.</p> <p>Luminance Waveform (Y)</p> <p>Display: A white/gray curve representing the overall brightness distribution of the frame.</p> <p>RGB Component Waveform</p> <p>Display: Independent red, green and blue channel waveform, presented side by side.</p> <p>YUV Waveform</p>



	<p>Separates color and luminance. Y represents the luminance signal, while U and V represent the blue-yellow and red-green chrominance signals respectively.</p>
 <b>Vector</b>	<p><b>On, Off</b></p> <p>The vectorscope is a professional tool dedicated to analyzing and monitoring the color information of a frame. It visualizes color saturation (vividness) and hue (tone) via chrominance signals in a circular graph to quantify the color data of the frame, enabling precise judgment for cinematographers and colorists. It serves as a color calibration benchmark for professional scenarios such as film and television production, live streaming, and broadcasting.</p>
 <b>Histogram</b>	<p><b>On, Off</b></p> <p><b>Mode: RGB1、RGB2、Y</b></p> <p>RGB1 Histogram: Displays the brightness distribution of the red, green, and blue channels separately, designed to judge color casts, monochromatic over/underexposure, white balance, and color gradation.</p> <p>RGB2 Histogram: The red, green, and blue channels are overlaid on the same coordinate system, with overlapping areas showing mixed colors</p> <p>Y Histogram: A tool for objectively judging exposure and tonal distribution. Ideal for monitoring overall exposure to prevent clipped highlights and crushed blacks, assisting with precise lighting setup and post-production.</p>
 <b>Focus Assist</b>	<p><b>On, Off</b></p> <p><b>Color : ( Red, Green, Blue )</b></p>

	<p><b>Peaking Level :you can adjust the peaking level after turning on ( 1 ~ 10 )</b></p> <p>Highlights the in-focus areas of the image to help photographers quickly and accurately judge focus position during manual focusing. Especially ideal for fast moving video, portrait, etc</p>
 <p><b>Embedded Audio</b></p>	<p><b>On, Off</b></p> <p>A visual audio level indicator tool for monitors that displays sound volume in real time and detects audio clipping (distortion). It resolves issues of being unable to hear audio while monitoring video or inaudible sound in noisy environments, ensuring audio-video synchronization and distortion-free recording. Ideal for live streaming, on-location shooting and filming in noisy settings.</p>
 <p><b>Over Exposure</b></p>	<p><b>On, Off</b></p> <p><b>Exposure Level : you can adjust the exposure level after turning on ( 10~100 )</b></p> <p>A real-time exposure assist tool that highlights overexposed areas in the frame with striped patterns for quick identification of blown-out highlights, ensuring accurate exposure , ideal for video shooting, portrait photography and outdoor high-light scenarios.</p>
 <p><b>Check Field</b></p>	<p><b>On, Off</b></p> <p><b>Mode : Red, Green, Blue, Mono</b></p> <p>Eliminate color interference, focus on exposure, focus, contrast and single-channel signal quality, and quickly judge the picture's brightness gradation, edge details and color channel issues.</p>
	<p><b>On, Off</b></p>

<p><b>False Colors</b></p>	<p>False Color is an exposure assist tool that maps the precise brightness value of every pixel in the frame to distinct colors corresponding to different brightness levels. It allows you to instantly check the exact exposure values across the entire frame and clearly visualize the light and shadow distribution of each specific area. Ideal for video shooting, portrait photography and outdoor shooting in complex lighting conditions.</p>
<p> <b>Time Code</b> (Only under SDI signal)</p>	<p><b>On, Off</b> <b>Mode: LTC, VITC</b></p>





**Mark**





<p> <b>Nine Grid</b></p>	<p><b>On, Off</b> <b>Color: Red, Green, Blue, Black, White, Gray</b></p> <p>A core auxiliary tool for professional shooting, primarily designed for rule-of-thirds composition. It divides the screen into equal grids of 9 cells for optimized framing.</p>
<p> <b>Safe Frames</b></p>	<p><b>On, Off</b> <b>Mode: 80%, 85%, 90%, 93%, 96%, 2.35:1</b> <b>Color: Red, Green, Blue, Black, White, Gray</b></p> <p>Prevent edge cropping of the frame, ensure subtitle/subject remain fully visible, and adapt to different playback devices.</p>
<p> <b>Center Marker</b></p>	<p><b>On, Off</b> <b>Color : Red, Green, Blue, Black, White, Gray</b></p>

 <b>Ratio Marker</b>	<p><b>On, Off</b></p> <p><b>Mode:</b> 4:3、13:9、14:9、15:9、16:9、1.85:1、2.35:1</p> <p><b>Color:</b> Red, Green, Blue, Black, White, Gray</p> <p><b>Modified Mark : 0~5</b></p> <p>Preview the target aspect ratio in real time, standardize framing, reduce post-production cropping, align shooting with the final footage ratio, and improve framing efficiency and footage precision.</p>
-------------------------------------------------------------------------------------------------------	-------------------------------------------------------------------------------------------------------------------------------------------------------------------------------------------------------------------------------------------------------------------------------------------------------------------------------------------------------------------------------------------







## Display

 <b>Scan Mode</b>	<p><b>Under Scan, Over Scan</b></p>
 <b>Aspect Ratio</b>	<p><b>Auto, 16:9, 16:10, 4:3, 5:4, 1.85:1, 2.35:1, Full Screen</b></p> <p>Match the shooting frame, eliminate picture distortion, and monitor precise composition to ensure the captured footage is restored without stretching or cropping in its original aspect ratio, adapting to various formats and creative requirements.</p>
 <b>Anamorphic</b>	<p><b>On, Off</b></p> <p><b>Mode:</b> 1.33X, 1.6X, 2.0X, 2.0X MAG, User</p> <p>Under the <b>User</b>, can be customized (1.20X~2.00X)</p> <p>Paired with anamorphic lenses, this function restores the horizontally compressed shooting image to the normal aspect ratio on the monitor for real-time framing and proportion checking. It resolves the issue of image squashing and inaccurate framing when shooting with anamorphic lenses.</p>

 <b>Image Flip</b>	<p><b>On, Off</b></p> <p><b>Mode: H Flip, V Flip, H_V Flip</b></p> <p>This function resolves abnormal screen orientation caused by special monitor mounting angles (e.g., upside-down, side-mounted) or restricted shooting perspectives. It ensures a correct, upright viewing angle for the screen regardless of the monitor's mounting or shooting position, without interfering with monitoring, focusing or framing.</p>
 <b>Zoom Mode</b>	<p><b>On, Off</b></p> <p><b>Mode: 2X、4X、9X、16X、User</b></p> <p>Under the <b>User</b>, can be customized (100%~200%)</p> <p>Magnify the central area of the screen for precise focusing, detail inspection and image quality verification.</p>
 <b>Image Freeze</b>	<p><b>On, Off</b></p>
 <b>P2P</b>	<p><b>On, Off</b></p> <p>Enable the filmmaker to check the image from the 1:1 signal source without scaling. This feature is essential for capturing optimum detail.</p> <p>A display mode that maps the monitor's input signal pixel 1:1 to its physical screen pixels, presenting the signal with no stretching, no scaling and no cropping to fully restore the original resolution and fine details of the input signal. It is an essential function for precise focusing, image quality inspection and framing calibration.</p> <p>Note: This function is only available when the input signal resolution <math>\leq</math> the monitor's physical resolution.</p>







## User

 <b>LUT</b>	<p><b>On, Off</b></p> <p>After the LUT Switch is turned on, you can use the <b>Lut (SLOG2, SLOG3, LOGC, VLOG)</b>.</p> <p><b>Lut Import: Confirm</b></p> <p>After copying the 3D LUT file to the USB flash drive and inserting it into USB adapter cable (USB-female to mini-USB) press MENU button <b>Confirm</b> to import the 3D LUT file.</p> <p><b>Lut Table</b></p> <p>Show the 4 built-in Lut and the custom load Lut (up to 32)</p>
 <b>Display Adjustment</b>	<p><b>Backlight: 0~100</b></p> <p><b>Brightness: 0~100</b></p> <p><b>Contrast: 0~100</b></p> <p><b>Saturation: 0~100</b></p> <p><b>Tint: 0~100</b></p>
 <b>Color Adjustment</b>	<p><b>Color Temp.: 5600K, 6500K, 9300K, User</b></p> <p>Under the <b>User</b>, the red, green and blue of the image can be adjusted (0~255)</p>
 <b>Shortcut Key</b>	<p>All Waves, Waveform, Vector, Histogram, Embedded Audio, Center Marker, Safe Frames, Nine Grid, Focus Assist, False Colors, Over Exposure, Anamorphic, Image Freeze, Check Field, Zoom, Image Flip, Aspect Ratio</p> <p>To set the 2 shortcut custom button F1, F2 on the</p>

	<p>panel</p> <p>e.g.: Press MENU button enter menu ,        ↓/↵ , ↑/↵ button select User and press MENU        to confirm. Then <b>F</b> Shortcut Key and press        MENU to confirm, select F1 and confirm to        pop-up function items, then select one of them        and press to confirm, the cursor will be changed        to gray color after confirmed. Same setting for F2</p>
--	----------------------------------------------------------------------------------------------------------------------------------------------------------------------------------------------------------------------------------------------------------------------------------------------------------------------------------------------------------------------------------------------------------------------



## System

 <b>Language</b>	<p>English、简体中文、Español、Português、Français、        Nederlands、Deutsch、日本語、繁體中文、한국어로、  <b>русский язык</b></p>
 <b>OSD Option</b>	<p>OSD Time: Off, 15Sec, 30Sec, 45Sec        OSD Trans: Off, 25%, 50%, 75%        No Signal: Red, Green, Blue, Black, White, Gray</p>
 <b>Volume</b>	<p><b>On, Off</b></p> <p>0~100</p>
 <b>Reset</b>	<p>Scroll the wheel to select <b>Reset</b> and press <b>Confirm</b>, the        system back to original setting.</p>
 <b>Firmware Update</b>	<p><b>Firmware Version</b> (display the current firmware version)  <b>Firmware Update</b>  <b>Confirm</b></p> <p>How to upgrade?</p>

	<p>1. USB flash drive format</p> <p>Support FAT32</p> <p>2. After copying the update file to USB flash drive insert to Type-C to USB adapter and connect with the TYPE-C interface of monitor , press MENU key <b>Confirm</b> to update.</p> <p>3. The monitor will turn off automatically after finishing, please turn on manually</p> <p>4. Check the firmware version whether the latest one</p>
--	-----------------------------------------------------------------------------------------------------------------------------------------------------------------------------------------------------------------------------------------------------------------------------------------------------------------------------------------------------------------------------------------------------

## 4. Custom LUT Load Instruction

### 4.1. USB flash drive format FAT32

### 4.2. Max Files Limit Maximum 32 Lut files

### 4.3. File requirements

- The LUT file format suffix should be **.cube**
- Single file not exceeded to 7.9Mb
- Support LUT-3D-Size 16,17,32,33,64,65

**Remark: LUT file name must be English or Arabic numerals**

### 4.4. Steps for loading

4.4.1 Make sure USB flash drive insert to Type-C to USB adapter and connect with the TYPE-C interface of monitor

4.4.2 Enter main menu  --LUT--**Lut Import** -- **Confirm** to load

the monitor will auto detect the USB flash drive

If there is valid lut file in USB flash drive, the monitor will load lut files and show “[n] name. The [n] shows the quantity number. The “name” should in lut files’ name. If load successful, the screen will show “complete[n]”. [n] Stands for the quantity number for lut files should under 32.

## PS: How to clear up the imported LUTs?

Insert a empty USB flash drive to the monitor, enter main menu  --LUT--Lut  
**Import -- Confirm**, the imported LUTs will be clear up.

## 5. Support Signal Formats

Signals	Support signal formats
HDMI	480i /480p /576i /576p 720p(60/59.94/50/30/29/25/24/23.98) 1080i(60/59.94/50) 1080p(60/59.94/50/30/29.97/25/24/23.98) 3840×2160p (23.98/24/25/29.97/30/50/59.94/60) 4096×2160p (23.98/24/25/29.97/30/50/59.94/60)
12G-SDI	1080i (60/59.94/50) 720p (60/59.94/50/30/29.97/25/24/23.98) 1080p (60/59.94/50/30/29.97/25/24/23.98) 3840×2160p (23.98/24/25/29.97/30/50/59.94/60) 4096×2160p (23.98/24/25/29.97/30/50/59.94/60)

## 6. Parameters

Panel Size	5.5" IPS LCD × 3
Resolution	1920 × 1080 pixels
Pixel Pitch	0.063(H)×0.063(V) mm
Color Depth	8bit
Aspect Ratio	16:9
Brightness	1000 cd/m <sup>2</sup>

Contrast	1000:1
Viewing Angle	80°/80°(L/R) 80°/80°(U/D)
Backlight	LED
Input Signal	12G-SDI, HDMI, Tally
Output Signal	12G-SDI, HDMI
Audio	3.5mm Audio Jack
Other Interface	TYPE-C ( Firmware update/ LUT import)
Power Input	DC 12V(suitable for 5.5x2.1mm power plug), 4-pin XLR
Input Voltage	DC 9~24V
Power Consumption	≤ 42 W
Special Function	TALLY indicator
Working Temperature	- 20~70℃
Storage Temperature	- 30~80℃
Unit Size	483L x 88.45H x 39D mm
Unit Weight	≈1890g

## 7. Trouble Shooting

If there is any problem when using the unit, please try following ways to inspect and solve. Please contact us if you still can not solve it or have other problems.

● **Without image display**

**Trouble shooting**

◆ Video cable off or connect incorrectly	Check the quality of the cable, make sure the correct input interface
◆ Without video signal input	Check the signal source and output interface connect is correct or not
◆ Monitor is not be powered on	Check whether the power is connected, click “  ” button to confirm.
◆ Supply voltage instability	The power adapter plug is poor connected with the socket
◆ self-contained power supply, polarity connect inversely	Reference "Power Input Way" and reconnect

● **Image/color display abnormal**

**Trouble shooting**

◆ Video cable poor contact	Change the video cable, try again
◆ Video signal interfered by external environment	Move to another environment to try again
◆ Video input signal amplitude too low	Check signal source video output, or change signal source and have a try.
◆ Menu color saturation adjustment closing	Enter menu to check color, or reset to factory settings

◆ Check Field set in mono or black & white	Reset Check Field, back to the color
◆ Image deformation	Reset the image ratio

**●Earphone without sound**

**Trouble shooting**

◆ Audio cable off or connection properly	Confirm connected with the corresponding input port
◆ Volume adjustment was closed	Reset the volume control and adjust to a proper position.
◆ HDMI cable poor Connected	Check the quality of cable, or change cable and have a try
◆ No sound after switch video signal	Check whether there is an AUDIO signal input in AV Mode.

**■ Remark:**

★If there are still other problems, please contact with our related technical persons.

★If there are changes without prior notice.