

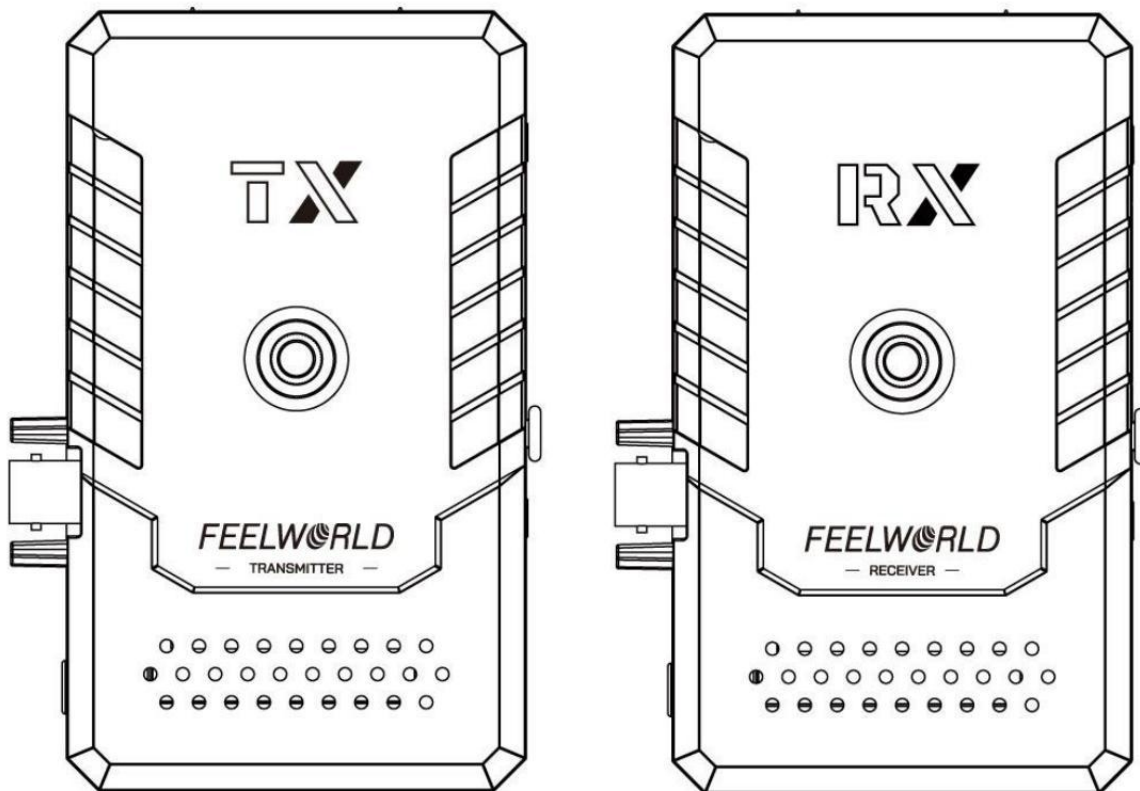

WTRS WTRH Wireless Transmission System

Recording | 4K HDMI | UVC Streaming



User Manual

Foreword

Thank you for purchasing FEELWORLD WTRS/WTRH wireless video transmission system. Equipped with TX/RX set which integrated with intercom, recording and live streaming. With 10Mbps high data rate, SDI (for WTRS) and HDMI ports and other features built for professional filmmaking, empowering filmmakers, crews, and content creators everywhere. Please read this manual carefully before using the product, wish you a happy experience!

■ Cautions

- Do not expose this device to extreme hot, cold, dusty or humid environments.
- Do not scratch the device with sharp objects.
- Do not drop this device from high place, as this may cause hardware damage.
- This device is designed for non-water proofing. Please do not allow any liquid to penetrate into the device.
- Do not attempt dismantle, open or repair this device by non-technical person, as this may cause permanent damage to the device.

■ Features

- Both TX and RX support recording, RX also support playback, fast forward and fast backward
- HDMI & SDI (optional) signal interfaces
- Transmission range up to 1000ft, with ultra-low latency 0.08S
- Up to 4K30Hz
- UVC streaming, make the live streaming more convenient and

smoother

- The transmitter can be switched as a receiver at will.
- Wireless full-duplex talkback, real-time intercom between the director and the photographer.
- One TX to multiple RX
- Support APP monitoring for Android/IOS system.
- 13 frequency channels, smart channel scan.

Content

Installation Instruction-----	4
Port Instruction-----	5
UI Instruction-----	7
Record & Playback Instruction -----	13
Streaming Instruction-----	14
APP Operation Instruction-----	22
Parameter-----	31
Frequency Chart-----	32

Installation Instruction

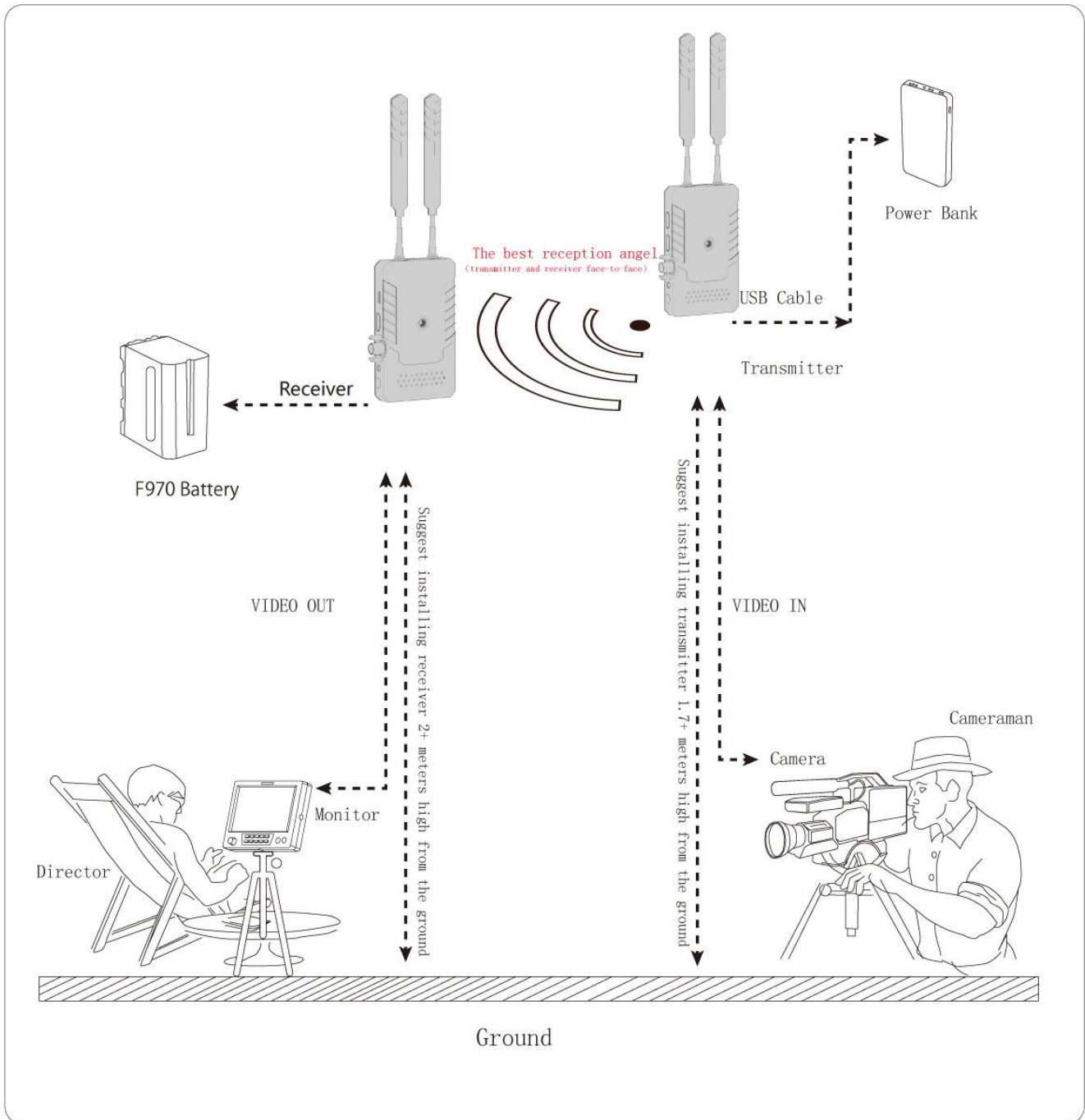

Port Instruction

Take WTRS for example

Transmitter

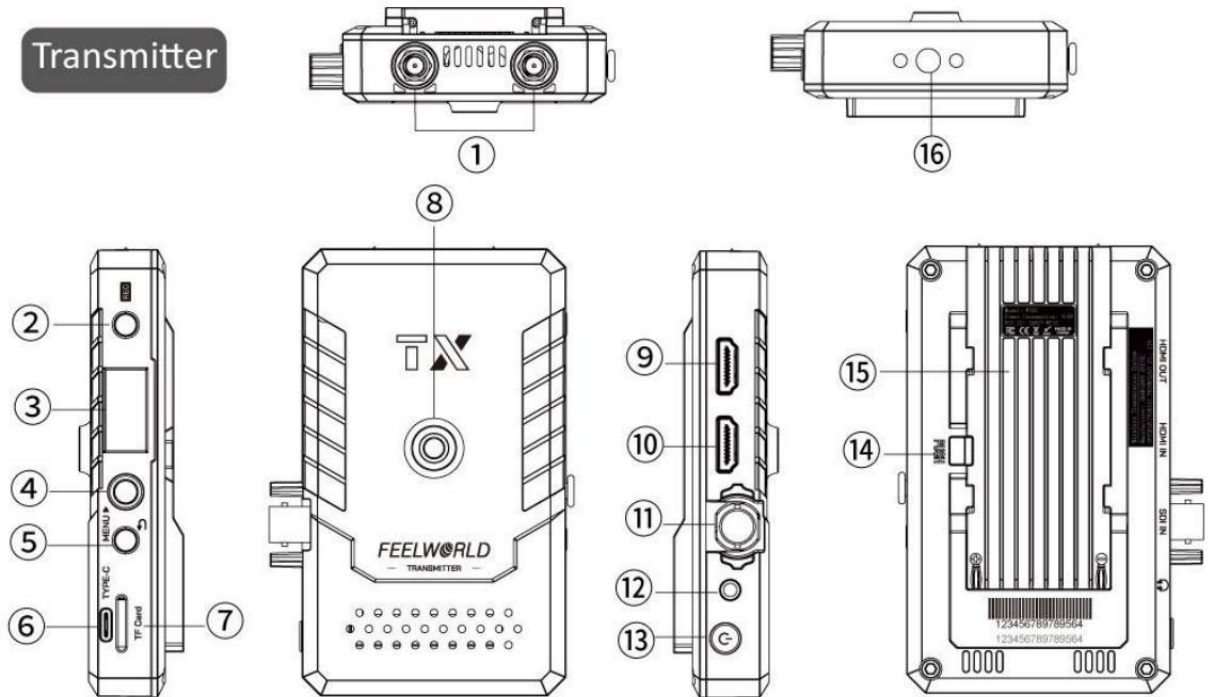

①: Antenna Ports

②: Record Button

③: Display

④: 5-direction Button (Menu control)

⑤: Menu return/exit

⑥: Type-C Power Port

⑦: TF Card Slot

⑮: NP-F Battery Slot

⑧: 1/4 Screw Hole

⑨: HDMI Signal Output

⑩: HDMI Signal Input

⑪: SDI Signal Input

⑫: 3.5mm Earphone Port

⑬: Power ON/OFF

⑭: Battery Release Button

⑯: 1/4 Screw Hole

Port Instruction

Receiver

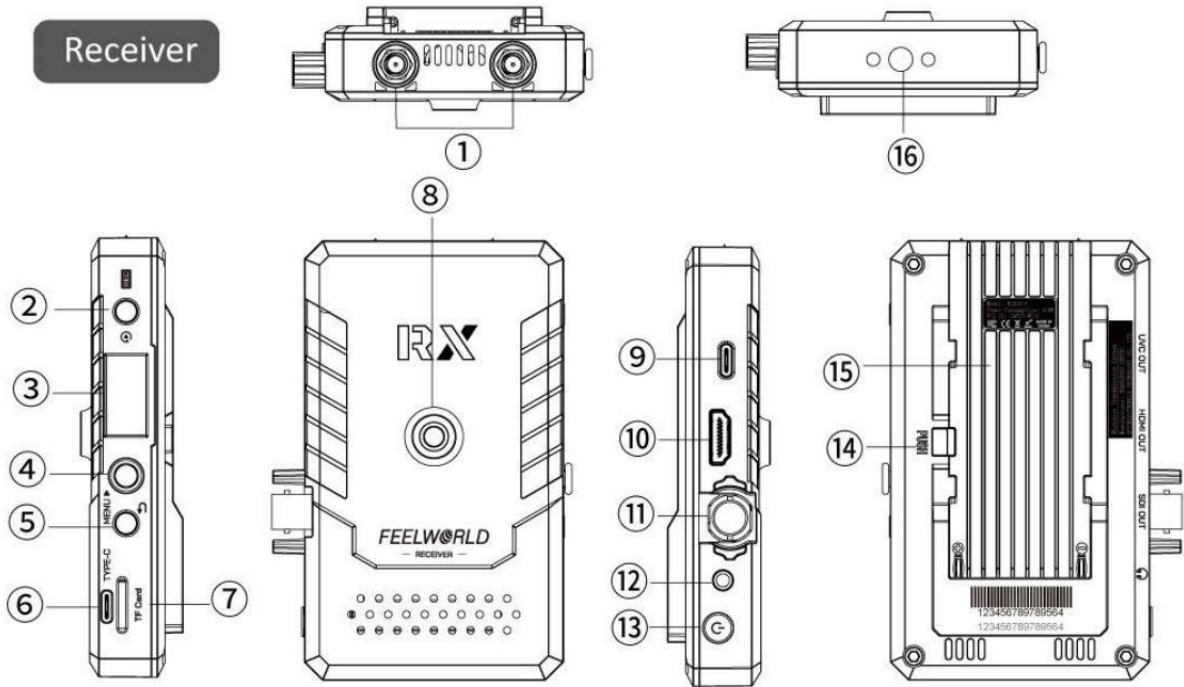

①: Antenna Ports

②: Record Button

③: Display

④: 5-directional Button (Menu control)

⑤: Menu return/exit

⑥: Type-C Power Port

⑦: TF Card Slot

⑮: NP-F Battery Slot

⑧: 1/4 Screw Hole

⑨: UVC Streaming Output

⑩: HDMI Signal Output

⑪: SDI Signal Output

⑫: 3.5mm Earphone Port

⑬: Power ON/OFF

⑭: Battery Release Button

⑯: 1/4 Screw Hole

UI Instruction

1. Startup

The startup screen is as below. When the device runs, the main menu will display.



2. Running Interface

Including channel, device type(TX/RX), link status, signal strength, video format, intercom mode, battery level, temperature, fan status, group display, etc. information.

Channel switch: Prod the 5-directional button up/down or left/right to directly select the channel, press the middle of 5-direcitional button to confirm after selection.

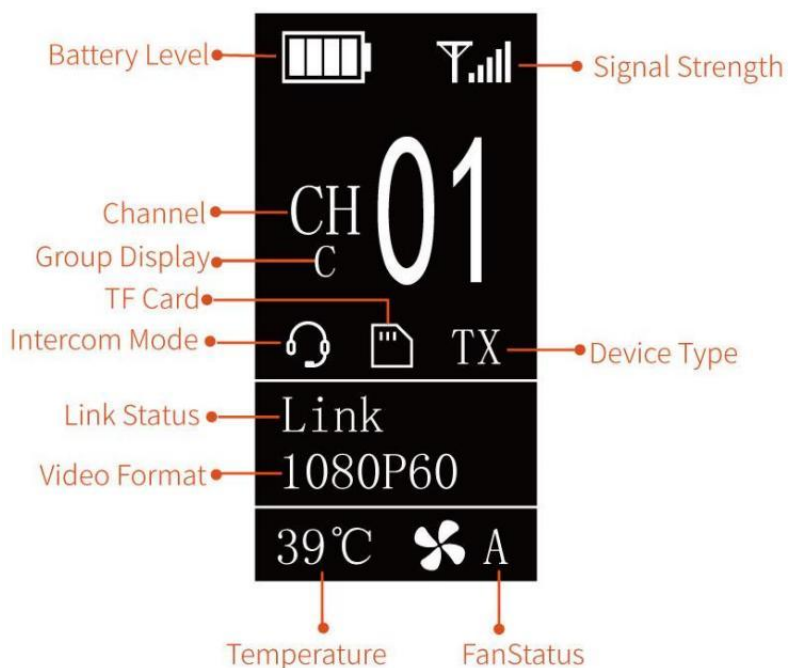

UI Instruction

3. Menu

Press the 5-directional button and hold for about 2 seconds to enter into the menu

Prod the 5-directional button up/down or left/right to select the menu, press the middle of directional button to confirm to enter into its menu, Then prod the 5-directional button up/down or left/right to select the function, press the middle of directional button to confirm finally.

Press ↶ button to return/exit the menu.

Device (transmitter only): device type

Switch TX (transmitter) and RX (receiver) manually.

Device

RX

TX

Intercom

Switch between Full Duplex, TD mode
(TD speak, Cameraman listen),

OFF(turn off intercom)

Intercom

Full Duplex

TD mode

OFF

UI Instruction

Fan Status

Adjust the level of fan or turn off fan manually.
(default to Auto)

Fan

Level Auto

About us

Check the telephone and website

Tel: 0596-2182566

Website: www.feelworld.cn

About us

Tel

Website

Language

There are English, 中文 for selection

Language

English

中文

WIFI_SSDI

Showing device name and password

UI Instruction

Version

Showing the device's version number

Version

V1.3.2

WLAN (TX)

Display Wifi name and password

WLAN

PassWD

WLAN

SSID:

FEELWORLD_5G_C

PassWD:

12345678

WLAN (RX)

Select PassWD to display Wifi name and password (note: the RX need to connect with TX firstly)

Select Scan, the device will scan the high quality channels automatically

WLAN

PassWD

Scan

UI Instruction

SD Card

If recording is not possible after inserting a TF (micro SD) card, it may be due to incompatible TF card format. You can enter this menu to format it first



SD Card
Format

Working Mode

Including Pairing and Grouping

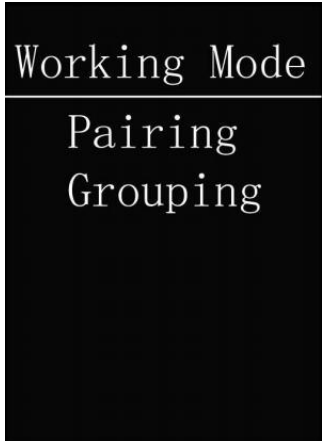

Working Mode
Pairing
Grouping

When select Pairing mode, you can pair the devices manually.

To pair transmitter and receiver. One Transmitter allows to pair 4 receiver maximum. Turning on WPS both for transmitter and receiver at the same time, then turn off the receive which finished pairing. Using the same pairing method to add next one receiver. Last, turning on all of the paired devices.



WPS Mode
ON/OFF

UI Instruction

When select Grouping mode, TX and RX can be paired automatically. You can set TX and RX in the same group and channel, such as TX is A CH03 RX also is A CH03, then they can connect automatically

Grouping

A	B
C	D
E	F
G	H
I	J

Record & Playback Instruction

Both TX and RX support real-time recording, RX also support playback, fast forward and fast backward.

1. Both TX and RX input the signal, and the HDMI OUT of RX connect to a display
2. Insert a TF card to the TF card slot, press the “REC” button start to record
3. Press the “REC” button again to finish the record and save
4. Press the “REC” button and hold it until the saved record files display, prod the 5-directonal button to select the record file which you would like to playback, press the middle of 5-directional button to confirm to play.

If you want to delete the record file, you can gently press the “REC” key to display the video file deletion option; toggle the 5-directional key to select "OK", then press the center of the key to confirm deletion



```
>FEELWORLD_video_4.mp4
```

```
FEELWORLD_video_3.mp4
```

```
FEELWORLD_video_2.mp4
```

```
FEELWORLD_video_1.mp4
```

“OK” delete, “back” back

5. During the playback, you can prod the 5-directonal button to fast forward or fast backward the video. Press the middle of directional button to pause.

Streaming Instruction

You can use the receiver of WTRS/WTSH 's UVC OUT port to use it as a webcam source, and you can recognize the webcam signal from the WTRS/WTSH on live streaming platforms like Zoom, YouTube, Facebook, Twitch, OBS, etc.

OBS Streaming

Video Capture

WTRS/WTRH is compatible with many third party steaming software, we recommend OBS, which is available to download on <https://obsproject.com/download>. Download the software and update to the latest version.

1. Click "+" icon

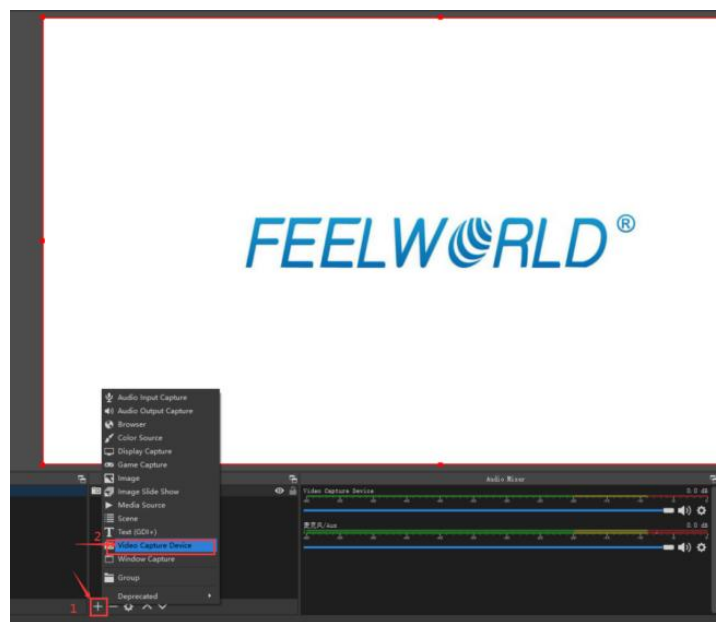

2. choose video capture device

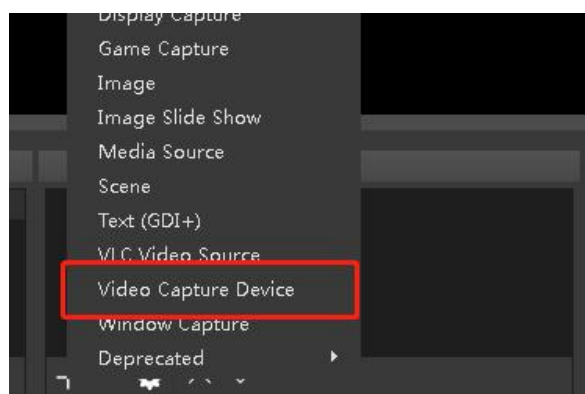

Streaming Instruction

3. Choose Device FEELWORLD and Choose Video Format YUY2 or choose the device default
4. The max resolution is 3840x2160

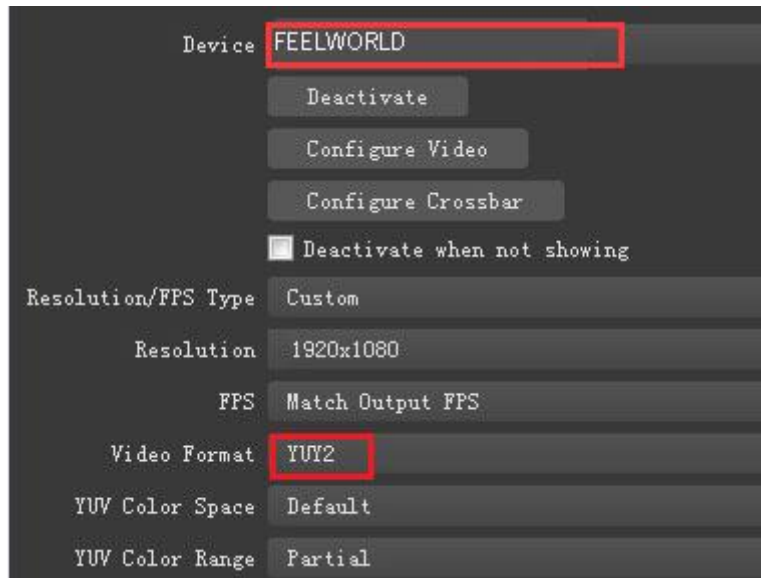

Audio Setting

When there is no audio playing first check the video source see if the it is set in default value and then check the audio setting on OBS.

1. Set Default for the audio source.
2. Audio setting on OBS.

Choose Audio, click Setting and choose audio device (Mic/Auxiliary Audio Device)

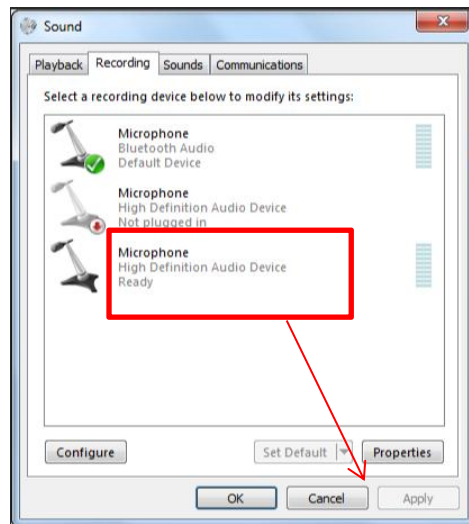

Streaming Instruction

Synchronize Video with External Audio

When the video itself doesn't have embedded audio and need insert external audio. Here are the steps



1. Set the audio source: Setting→Audio→Mic/Auxiliary Audio Devices

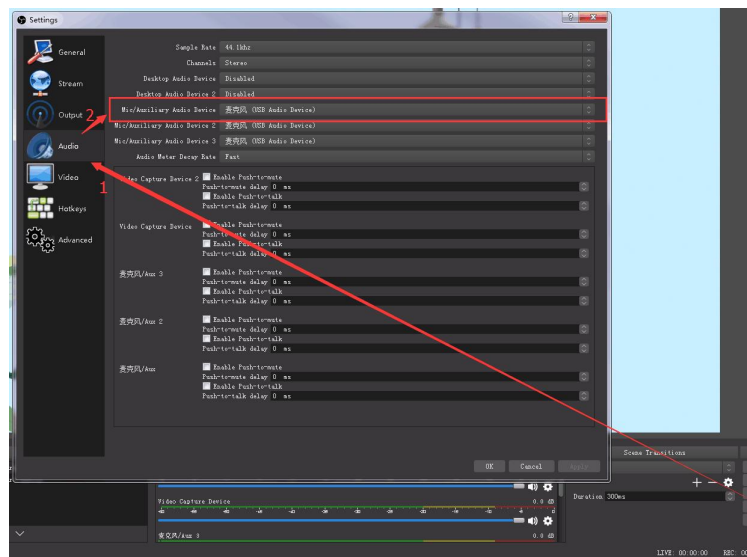

2. Right click the Video Capture Device in Source and choose Filter

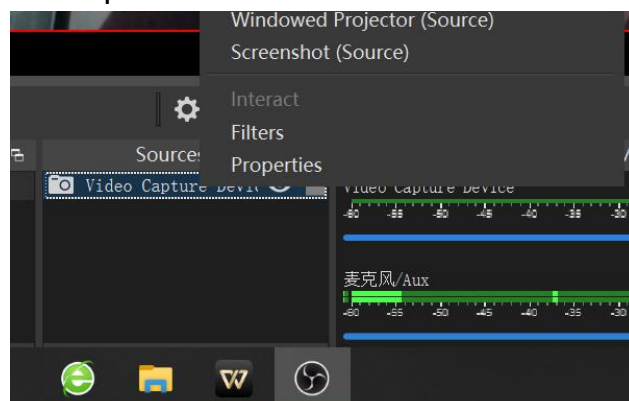

Streaming Instruction

3. Click “+” under Audio/Video Filters and choose Video Delay (Async)

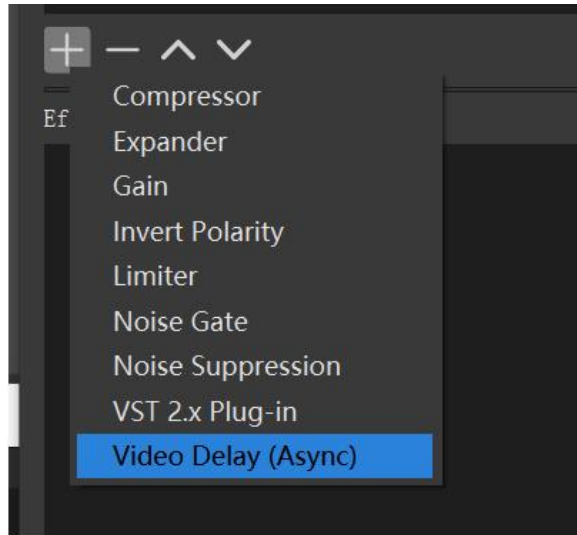

4. You can custom the filter name in the pop-up window. Click OK to confirm the filter name.

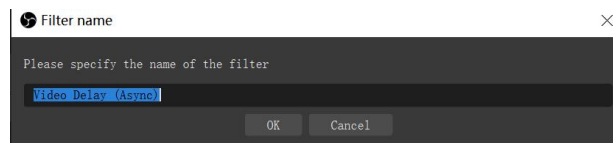

5. Input delay value in ms, the value need to adjusted until the video and audio is synchronous.

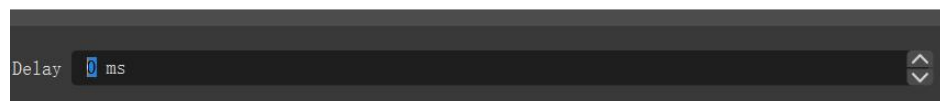

Streaming Setting

1. Find the RTMP URL and Stream Key provided by streaming broadcast website.
2. Copy URL and Stream Key
3. Back to OBS, click Setting in the lower right corner and click “Stream”. Choose Stream Type as “Streaming Service” or “Custom Streaming Server”. If choose “Streaming Service”, there is a list of streaming service name available in the drop down list of Service. If the streaming service is in the list, choose it from the list. If choose Custom Service, just fill in URL and Stream Key.

Streaming Instruction

vMix Streaming

WTRS/WTRH streaming via vMix steps are as follow:

1. Click a new blank, then click the “Add

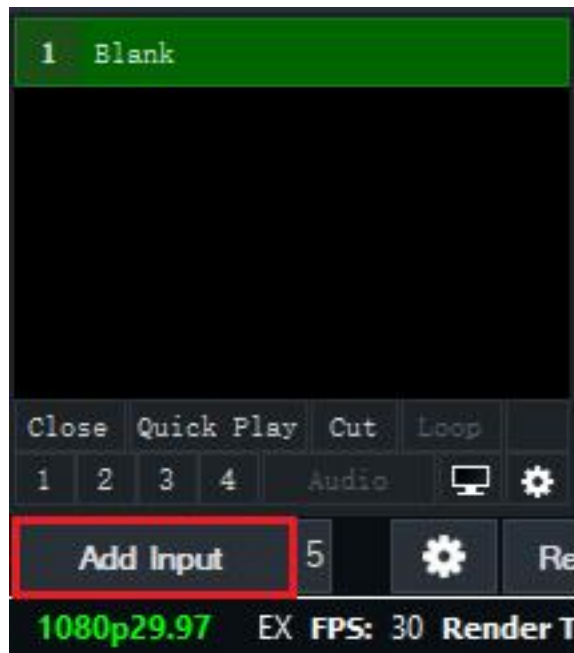

2. Select Camera-Camera-FEELWORLD

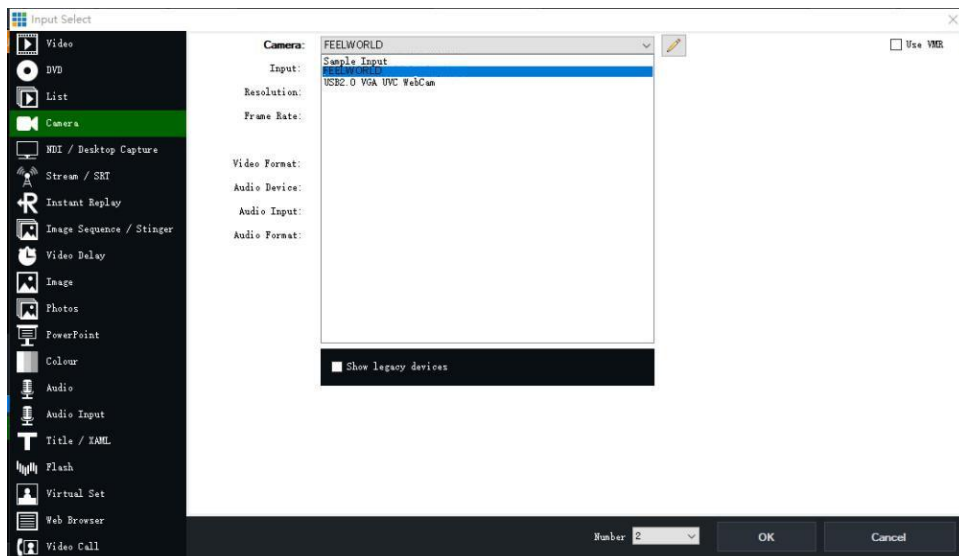

Streaming Instruction

3. Select the same resolution as the output. Then click “OK”.

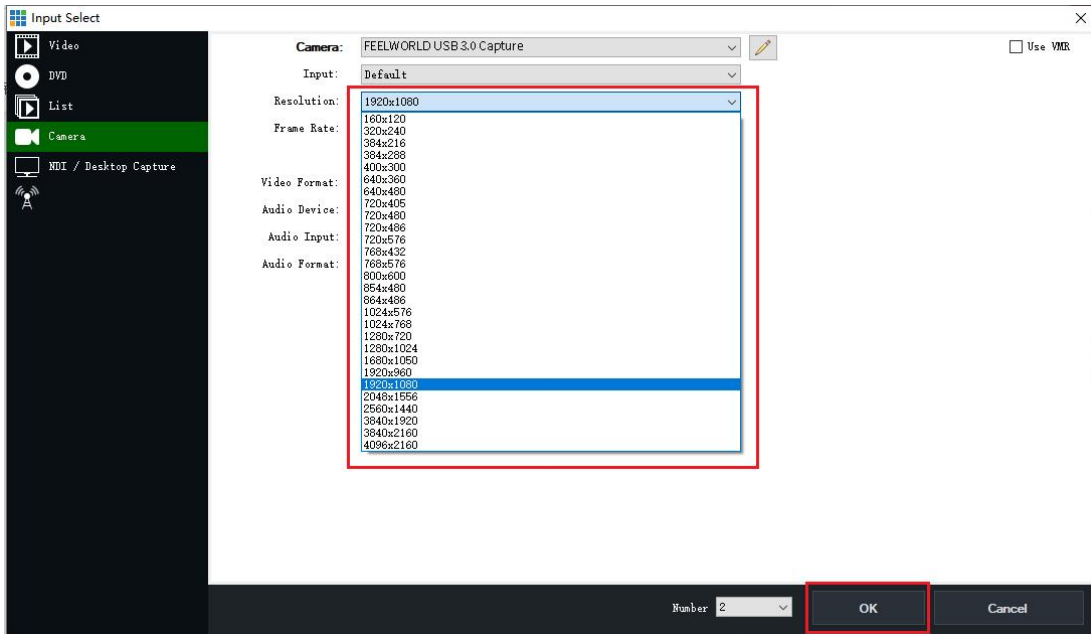

4. Click “Stream” setting button.

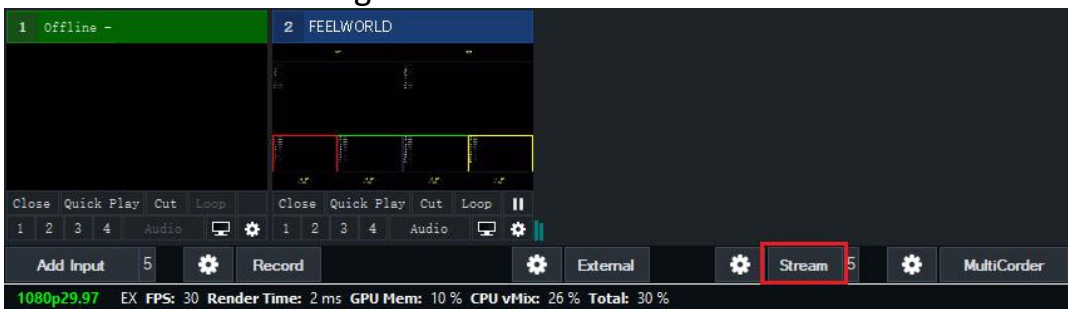

5. Complete the URL and Key information. Click “Start 1”, vMix will begin streaming.

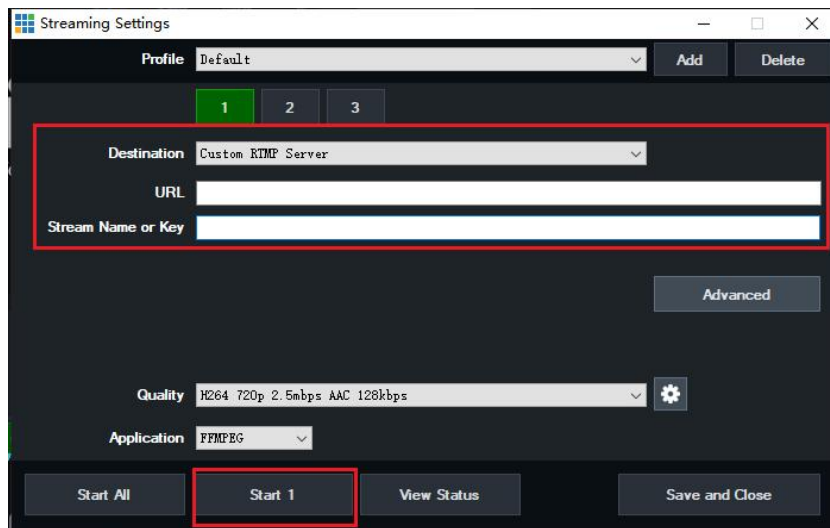

Streaming Instruction

Note: vMix does not support automatic recognition of the output resolution of WTRS/WTRH. Every time the output resolution of WTRS/WTRH is modified, the picture on vMix will pause. The user needs to re-select FEELWORLD and manually input the current output resolution of WTRS/WTRH.

APP Operation Instruction

1. APP Download

iOS APP Download



iOS user search “feelworld wireless 2” to get

Android APP Download (You can get the monitoring function from Android APP at present, the recording and other functions such as waveform, histogram, etc. are developing)

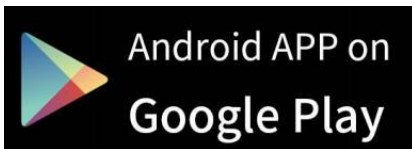

Search “ feelworld wireless 2” on Google Play to get



Scan the QR code to download

2. Connect smart devices to transmitter

When first using, after the transmitter is powered on, go to Setting-Wireless & networks on smartphone/tablet, select the transmitter’s name and input the password, then click “join” to connect the device. Please find the transmitter’s name and initial password as below. Then enter to APP and click “Go” to enter monitoring interface.

APP Operation Instruction

Device name: FEELWORLD_5G_XXXXX

Password: 12345678

When use again, after the transmitter is powered on, enter to APP then click “Go” and follow the prompts to join the network. After successful connection, click Go to enter the monitoring page.

2. APP Operation (e.g. iOS system)

- a. Click  pop up all monitoring auxiliary functions
- b. Click on the corresponding monitoring function to add it to the top of the screen as a shortcut bar
- c. After adding, all added functions will be displayed at the top, and clicking on the corresponding function can quickly turn it on or off

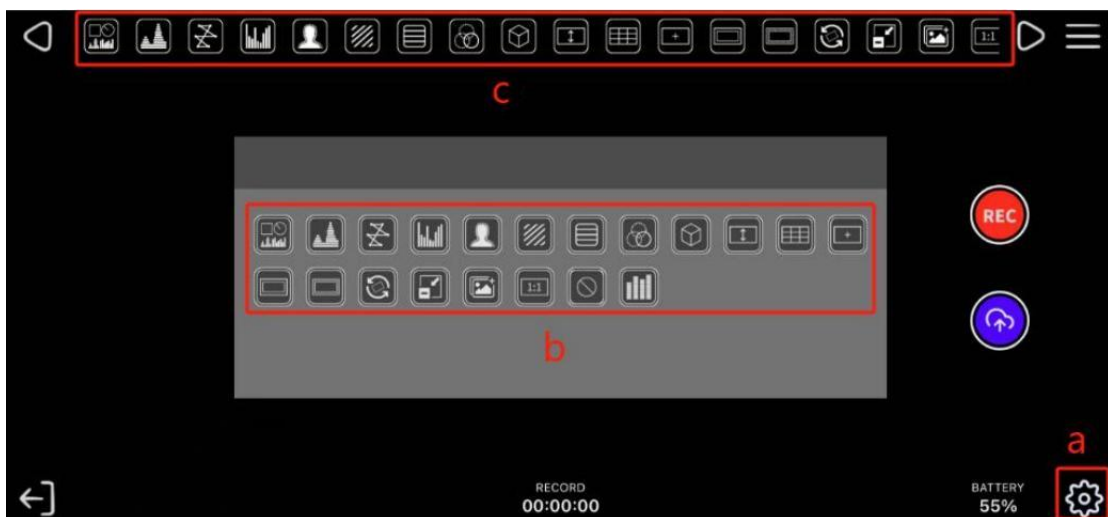

APP Operation Instruction

Function Settings and Instructions

Click  to set most of functions



All waves

After turning on, waveform, vector, histogram will be shown.



Waveform

This essential feature assists with the calibration of professional video cameras. It shows the overall brightness of the image assisting the video professional in correcting exposure. The waveform feature also checks the evenness of the lighting when lighting a chromakey or background.

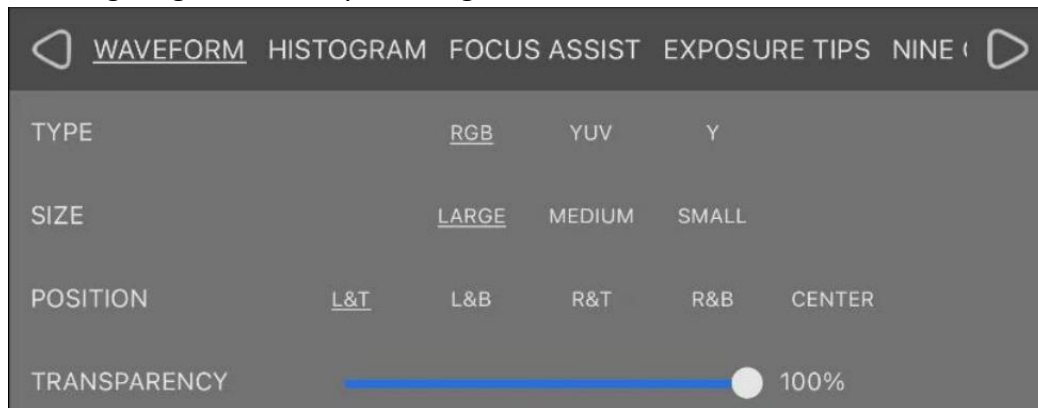

Vector

Shows how saturated the image is and where the pixels in the image land on the color spectrum.



Histogram

RGB Histogram: It can display the graphic of color tone distribution, can intuitively display the exposure status of the image, and display overlapping histograms in red, green, and blue channels

Y Histogram: A quantitative tool to check the picture brightness, display different color for different brightness

APP Operation Instruction



Focus Assist

It highlights the areas that are in focus so you are able to quickly focus the camera and not miss crucial shots.

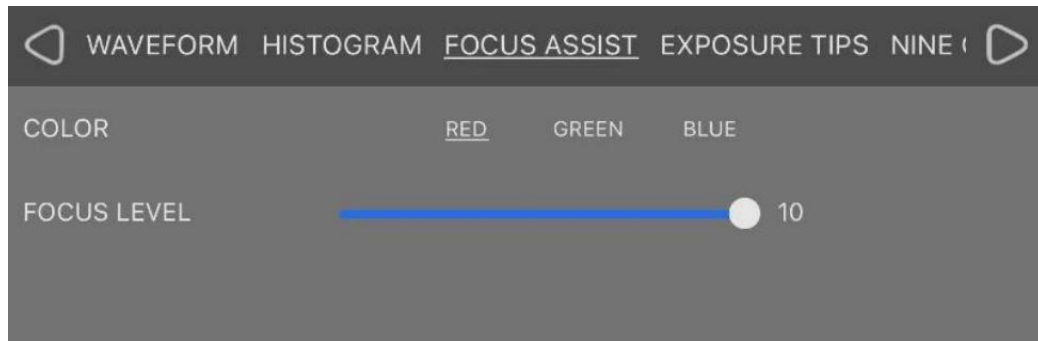

Exposure Tips

Areas of the image over a certain threshold are filled with a striped pattern to dramatically highlight areas where too much light is falling on the image sensor.

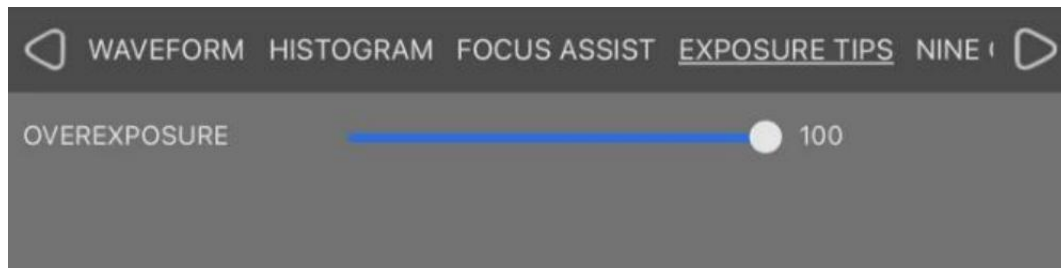

False Colors

An image that depicts an object in colors that differ from those a photograph (a true color image) would show.



Monochrome Display

When enabled, hue and saturation adjusted quickly and accurately

APP Operation Instruction



: LUT

LUT is a table for quickly looking up and output specific color data. By loading different 3D-LUT tables, it can quickly recombine color tone to form different color styles.

Click “ LUT SELECTION” to select, built-in 4 Luts

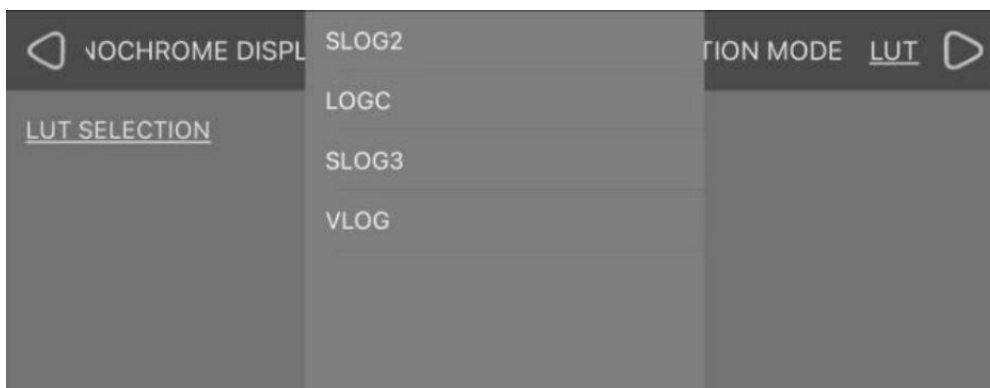

: Deformation Mode

Allows you to use anamorphic lenses or adapters and see the image unsqueezed, even if your camera does not de-squeeze in camera.



APP Operation Instruction

Click "CUSTOM" can be set range 1.0x~2.0x. After key in the value, then click  and the value will be display the **TYPE** list

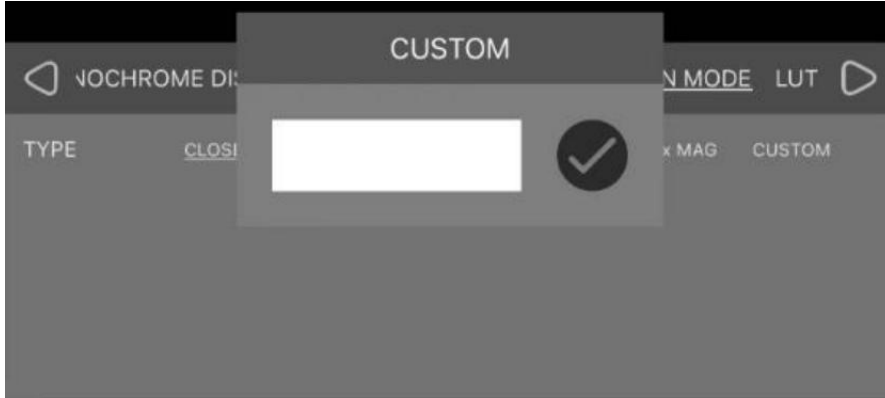

: **Nine Grid**

The area of the picture can be divided into equal grids



Click "CUSTOM" can be set the number among 2~100. After key in the number, then click  and the number will be display the **TYPE** list

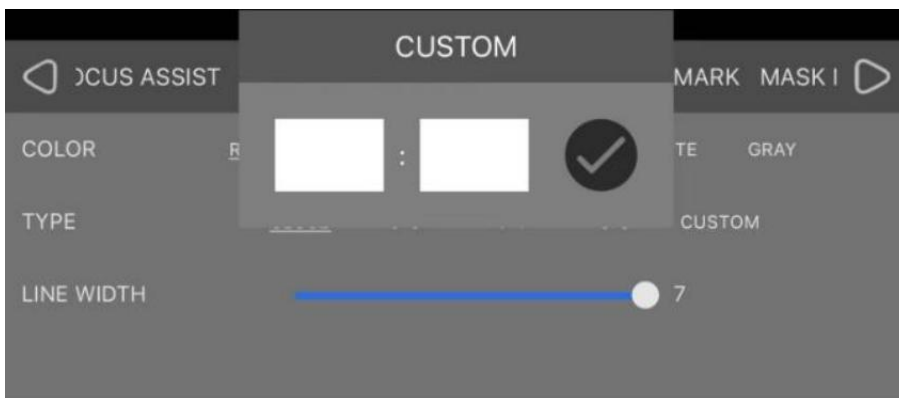

APP Operation Instruction



Center Mark

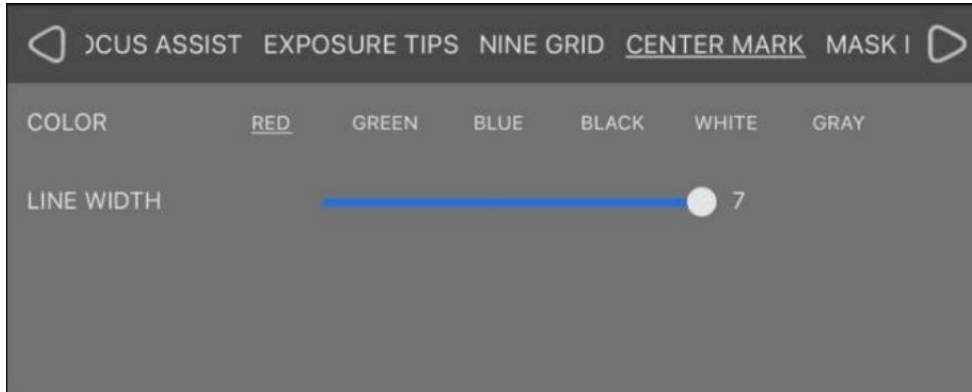

Safety Frame



Mask Mark



APP Operation Instruction



: Image Flip



: Scan Mode

Click the icon which on the shortcut column directly, click first time is “Under Scan”, click second time is “Over Scan”.



: Pixel to Pixel

Enable the filmmaker to check the image from the 1:1 signal source without scaling. This feature is essential for capturing optimum detail.



: Image Freeze



Image Overlay

Click “ IMAGE SELECTION” to select the image to overlay

Note: The selected image can only be a screenshot image from the APP

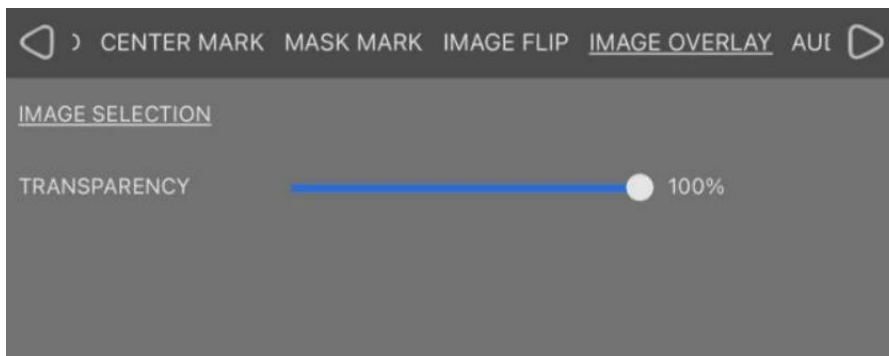

APP Operation Instruction



: Audio Column

Provide numerical indicators and headroom levels.

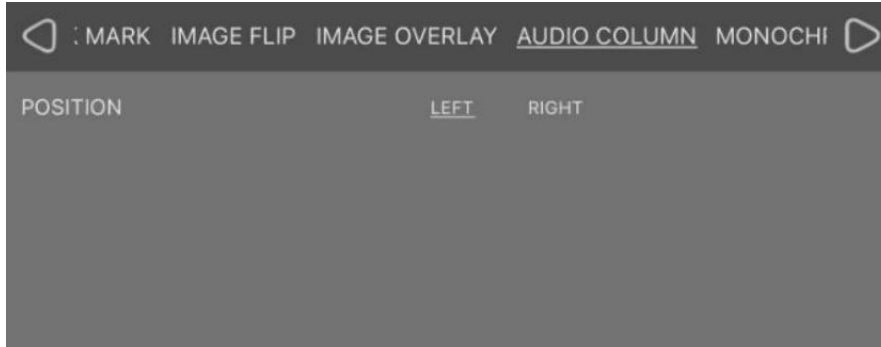

: RECORD



: Click to pop up the recorded video

Parameter

	Transmitter	Receiver
Screen	OLED	OLED
Interface	1 * SDI input (optional) 1 * HDMI input, 1* HDMI output 2 *Antenna port (RP-SMA Male) USB-C power input 3.5mm headphone jack TF (micro SD) Card Slot	1* SDI output (optional) 1* HDMI output 1* UVC out 2 *Antenna port (RP-SMA Male) USB-C power input 3.5mm headphone jack TF (micro SD) Card Slot
Power Supply Way/Voltage Range	NP-F battery slot , Type-C: 5V/3A	NP-F battery slot , Type-C: 5V/3A
Power Consumption	<4.4W	<6.4W
HDMI Input/Output Video Format	480P60, 576P60 720P60/59.94/50 1080P60/59.94/50/30/29.97/25/24/ 23.98 1080I60/59.94/50 2160P30/25/24 HDMI Type A	480P60, 576P60 720P60/59.94/50 1080P60/59.94/50/30/29.97/25/24/ 23.98 1080I60/59.94/50 2160P30/25/24 HDMI Type A
SDI Input/Output Video Format	480P60, 576P60 720P60/59.94/50 1080P60/59.94/50/30/29.97/25/24/ 23.98 1080I60/59.94/50 1*BNC	480P60, 576P60 720P60/59.94/50 1080P60/59.94/50/30/29.97/25/24/ 23.98 1080I60/59.94/50 1*BNC
Frequency	5.1-5.9GHz	5.1-5.9GHz
Modulation Mode	OFDM	OFDM
Transmission Power	22dBm	/
Receiving Sensitivity	/	-87dBm
Band Width	20/40MHZ	20/40MHZ
Latency	Min0.08S	Min0.08S
Intercom Frequency Response Range	20Hz~20KHz	20Hz~20KHz
Recording Format	MP4	MP4
TF (micro SD) card storage capacity	Max support 256G	Max support 256G
Encoding Format	Video H.264; Audio AAC	Video H.264; Audio AAC

1080p60 Bitrate	3222kbps	3222kbps
4K30 Bitrate	5082kbps	5082kbps
Operating Temperature	0°C ~ 40°C	0°C ~ 40°C
Storage Temperature	-20°C ~ 60°C	-20°C ~ 60°C
Unit Size(mm)	81.87L*28.1W*120.5H (excluding antenna)	81.87L*28.1W*120.5H (excluding antenna)
Unit Weight	126g	126g

Frequency Chart

Device Channel	WiFi Channel	Frequency/MHz
AUTO-9	AUTO	AUTO is the best
10	48	5240
11	44	5220
12	149	5745
13	165	5825

Common Problem

1. The screen appears mosaic or the signal connection is unstable
It means that there is a WIFI signal close to the transmission frequency, you can re-select another channel. (Note: only the receiver is allowed to adjust the channel)
2. When the transmitter and receiver cannot be connected in pairing mode.
Please turn off the transmitter and receiver, then turn them on again at the same time, and turn on the WPS mode to pair again.
3. When signal frequency is weak
Please try to choose another channel with a wider frequency span. (For instance, the signal of channel 8 is weak, please choose channel 1 or 5, but not channel 7 or channel 9).
4. The poor WIFI reception of the mobile phone
It is related to the brand and model of the mobile phone. Please try different mobile phones.

★ As we are improving product features and product performance, so if there is any change on the specification without prior notice.